

These drawings and specifications are the property of H2W Technologies, Inc. They are issued in confidence and shall not be reproduced, copied, or used without written permission from H2W Technologies, Inc.

REVISION TABLE					
REV	ECN#	DESCRIPTION	REV BY	APPROVED	DATE
---	---	Original Drawing	OOG	MPW	12-28-10

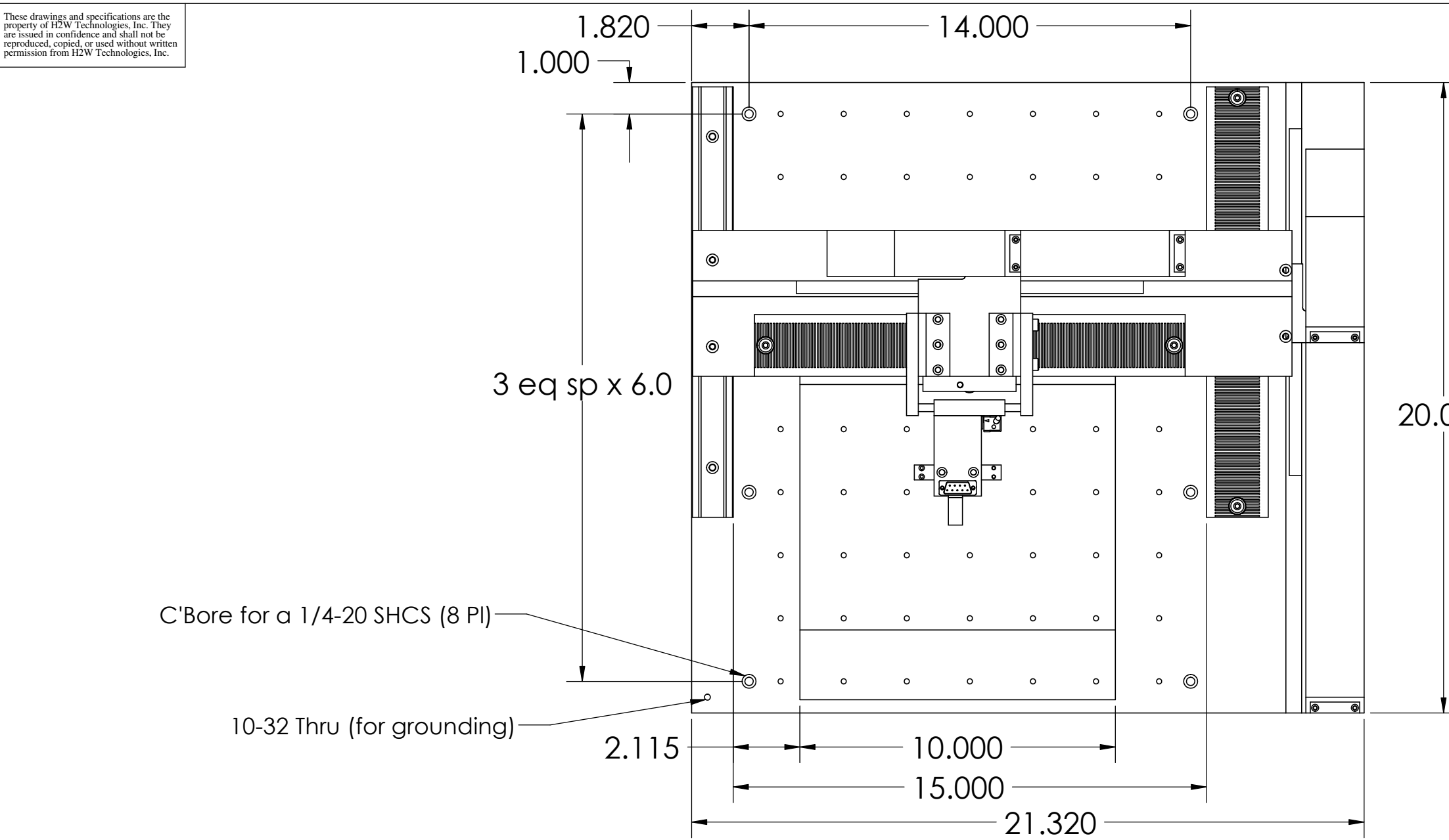

**Specs:**  
 X & Y Axis (Linear Stepper Motor)  
 Stroke = 10.0 in  
 Force = 6 lbs  
 Encoder = 1 micron  
  
 Z Axis (Voice Coil Stage)  
 Stroke = 1.0 in  
 Force (Cont) = 2.3 lbs  
 Force (Peak) = 6.9 lbs  
 Encoder = 1 micron  
 Load Cell = 0.1-1.0 lbs  
 Angular Adjustment = 0°-30°

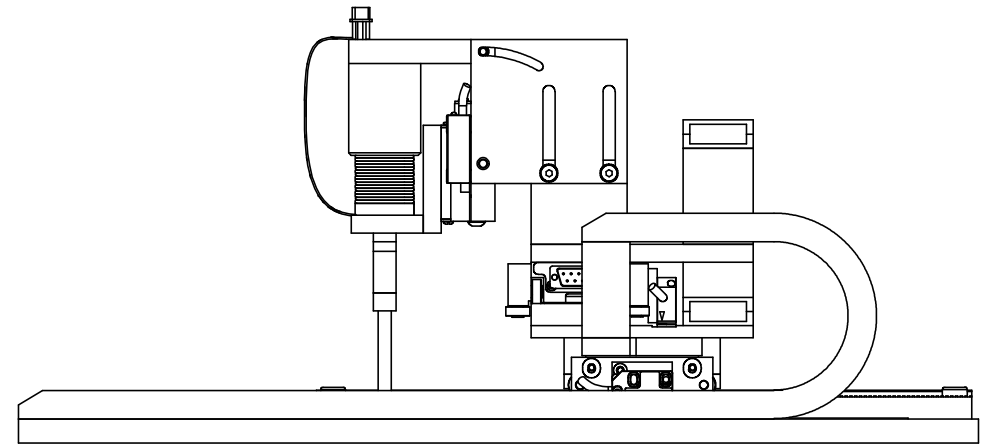
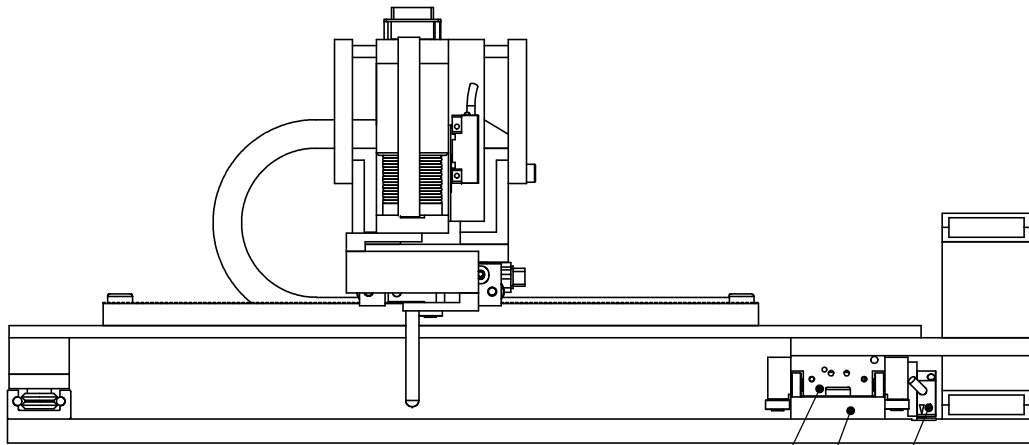
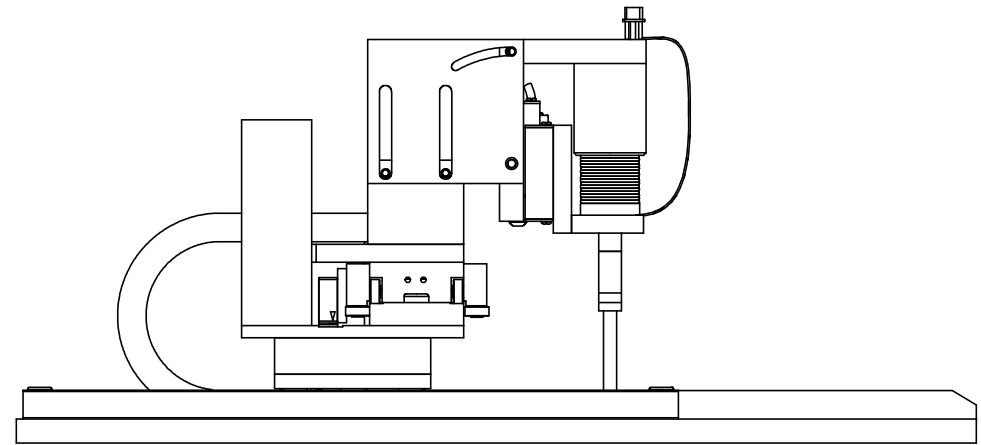

Stepper Motor  
 Platen  
 Linear Encoder  
 (Magnetic)

**H2W Technologies, Inc.**  
 26470 Ruether Ave #102 Santa Clarita, CA 91350 USA  
 Tel: (661) 251-2081 Fax: (661) 251-2067  
 www.h2wtech.com

UNLESS SPECIFIED OTHERWISE: All dimensions are in inches Standard Tolerances are as follows .XXX ±.005 ANGLES ±1° .XX ±.010 FILLETS AND .X ±.020 CORNERS .010 Remove All Burrs and Sharp Edges				MATERIAL		TITLE	
				FINISH		Multi-Axis Positioning Stage XYZ Gantry	
DRAWN	DATE	APPROVED	DATE	DWG #	REV	SHEET	
OOG	12-28-10	MPW	12-28-10	10-0471	---	1 of 4	

These drawings and specifications are the property of H2W Technologies, Inc. They are issued in confidence and shall not be reproduced, copied, or used without written permission from H2W Technologies, Inc.

# Voice Coil Axis Angular Adjustment

Straight

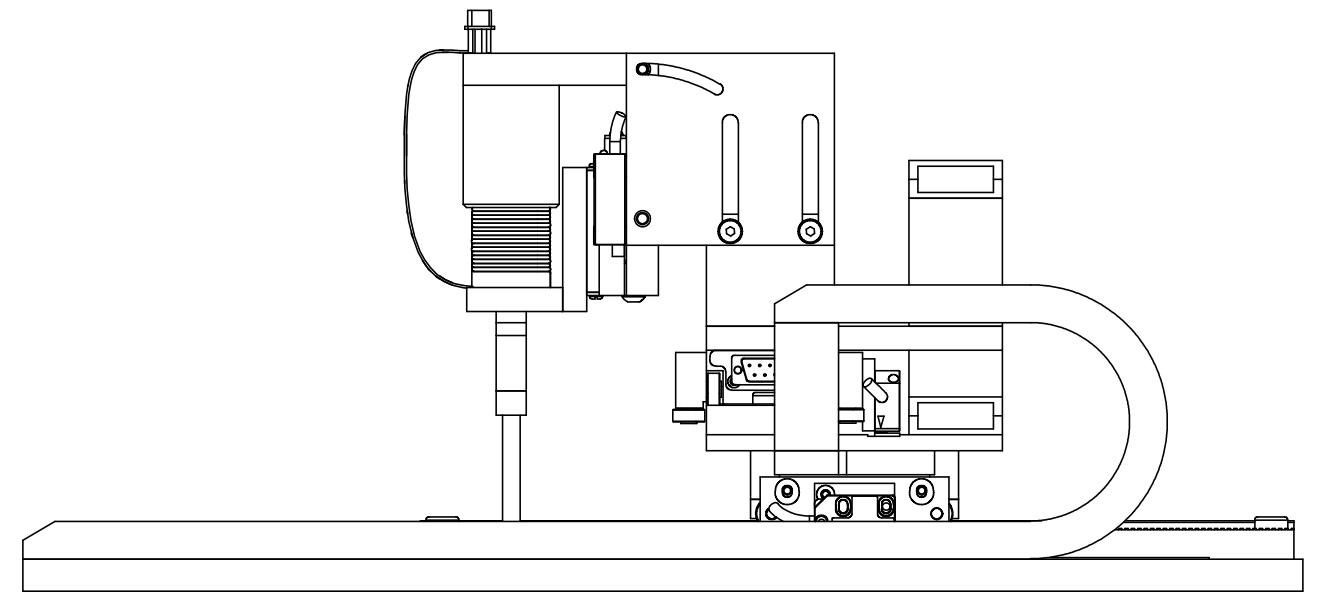
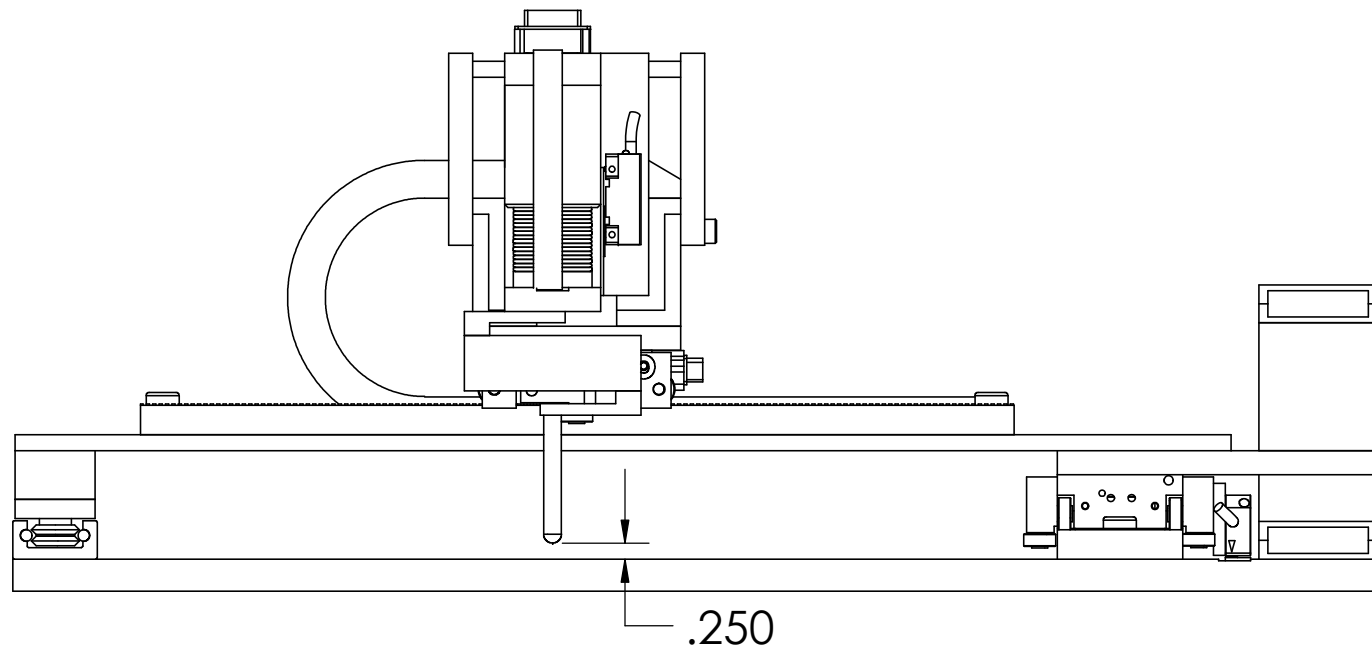

30 Degree Angle

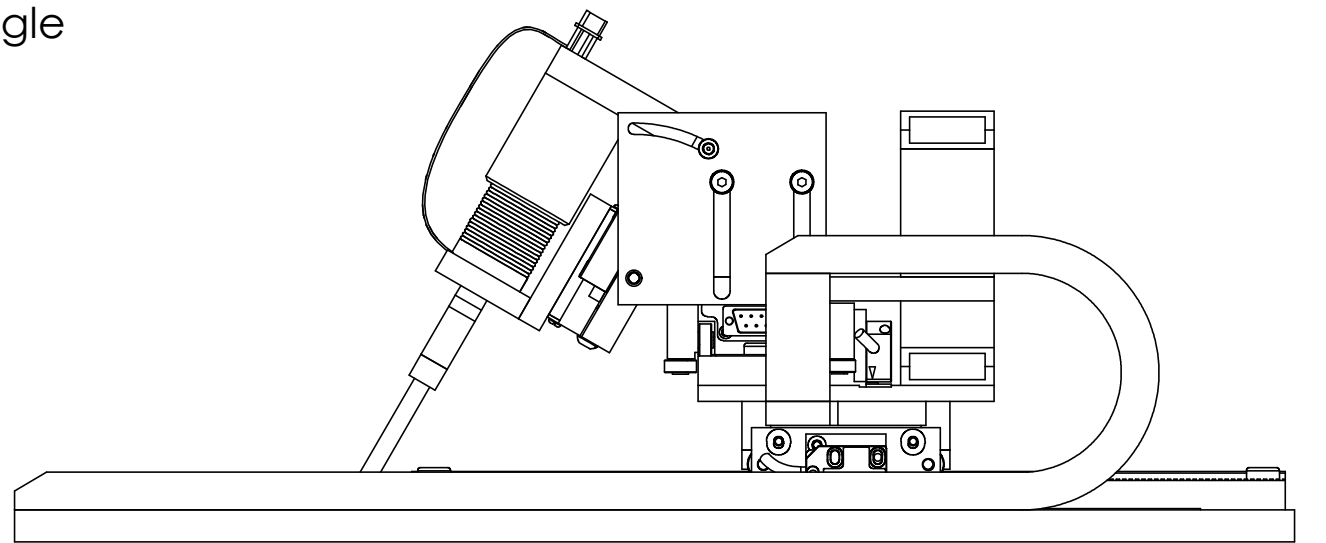
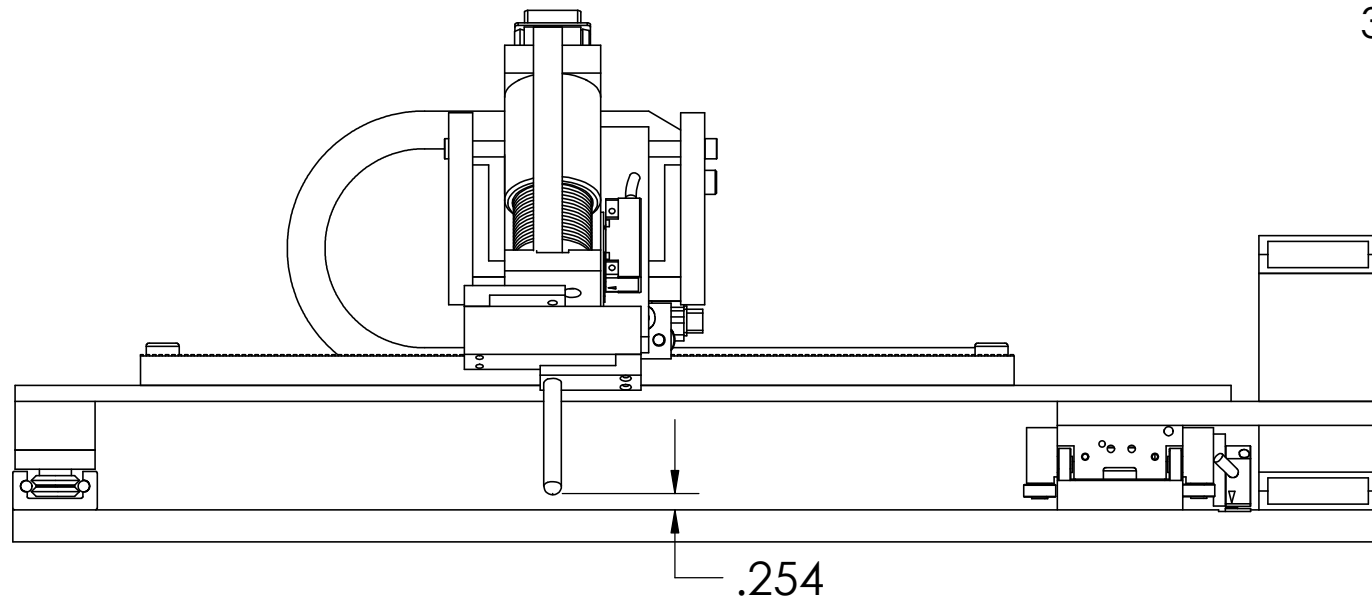

Voice Coil Stage Shown Fully Extended

TITLE	Multi-Axis Positioning Stage XYZ Gantry		
DWG #	10-0471	REV	---
		SHEET	2 of 4

These drawings and specifications are the property of H2W Technologies, Inc. They are issued in confidence and shall not be reproduced, copied, or used without written permission from H2W Technologies, Inc.

# PARTS HAVE BEEN HIDDEN TO SHOW GRID

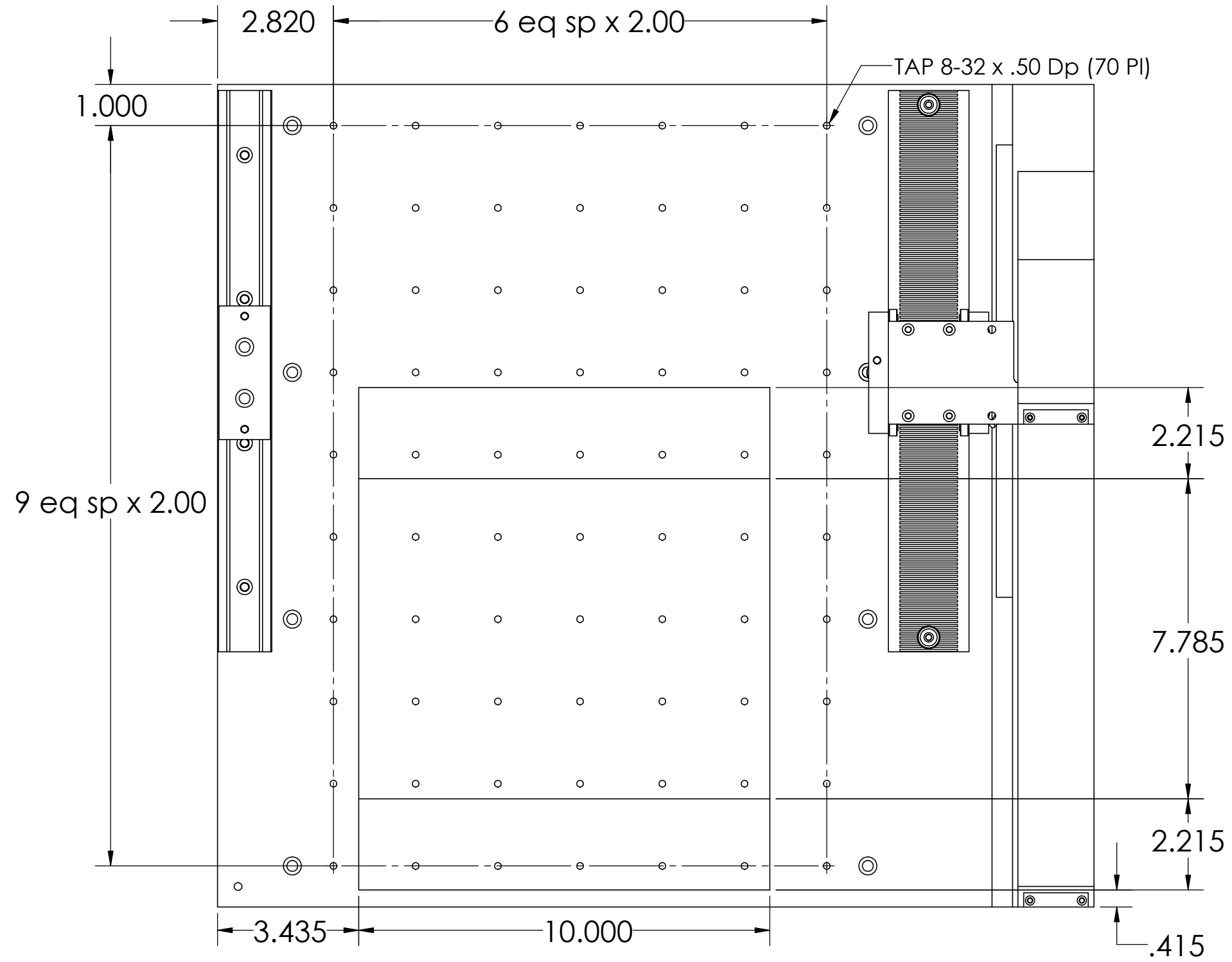

TITLE			
Multi-Axis Positioning Stage XYZ Gantry			
DWG #	REV	SHEET	
10-0471	---	3 of 4	

These drawings and specifications are the property of H2W Technologies, Inc. They are issued in confidence and shall not be reproduced, copied, or used without written permission from H2W Technologies, Inc.

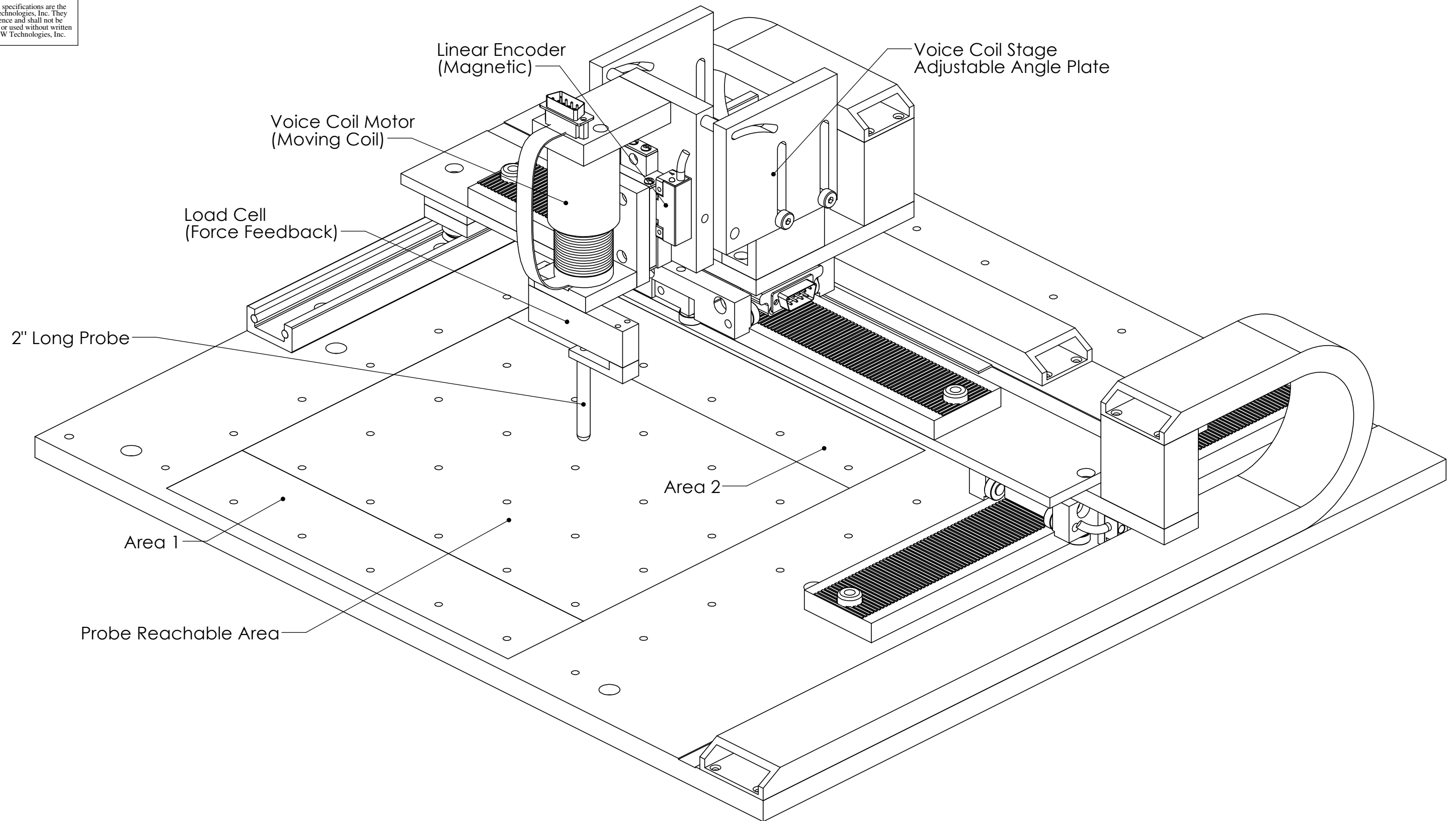

NOTES:

- Area 1 is only reachable when the vertical voice coil stage is at a  $30^\circ$  angle
- Area 2 is only reachable when the the vertical voice coil stage is at a  $0^\circ$  angle

TITLE	Multi-Axis Positioning Stage XYZ Gantry		
DWG #	10-0471	REV	---
SHEET	4 of 4		